

Dept	
Qty	
DC	1
ED	1
IE	1
ISO	1
PD	1
R&D	1
SD	1
QA	1
QC	1
QE	1

The information provided herein is from CONNELY Electronic Co., Ltd. and is confidential. Any disclosure to a party other than the recipient is prohibited. The intellectual properties and its rights contained herein, including but not limited to, trademarks, patents, copyrights, trade secrets, and technical know-how, are owned exclusively by CONNELY or its affiliates. Unauthorized use or modification is strictly prohibited. CONNELY may enforce its intellectual property rights at its own discretion, failure or delays to exercise such rights does not constitute a waiver of such rights.

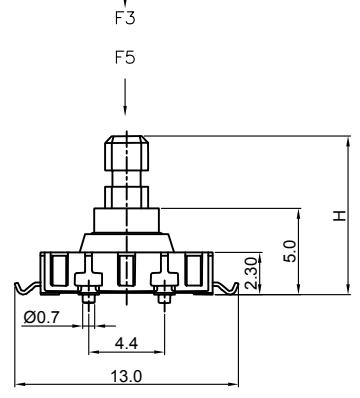

	①	②	③	④	⑤	⑥
F1	○			○		
F2	○	○				
F3	○				○	
F4	○			○		
F5	○		○			

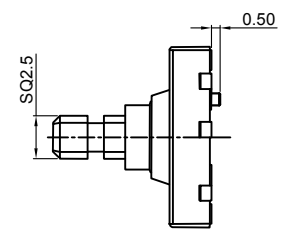
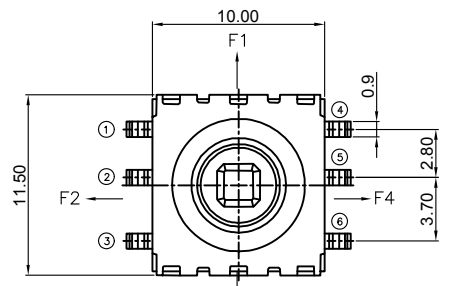
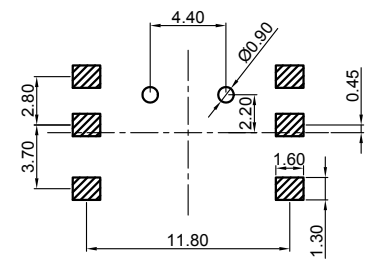
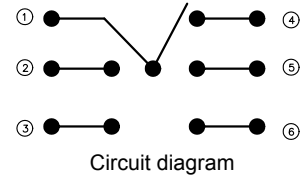

Recommend PCB layout
Tolerance:±0.05



(Series Image-Reference Only)

REV.	DESCRIPTION	DRAWN	CHECKED	APPROVED
A	NEW RELEASE	JLZ 05/12/18'		

NOTES:

- Specifications:
 - Contact Rating: 50mA at 12V DC
 - Insulation Resistance:100MΩ min.
 - Contact Resistance:80mΩ max.
 - Dielectric Withstanding Voltage: 250V AC(rms) for 1 minute.
 - Operating Life:50,000 cycles
 - Travel:0.2±0.1mm
 - Operation Temperature Range: -30°C to +85°C
 - Wave Soldering: Recommended Solder Temperature at 500°f(260°C)max. 5 Seconds
 - Hand Soldering: Use Soldering Iron Of 30 Watts,Controlled at 608°f(320°C) Approximately 2 Seconds.
- Product number code:

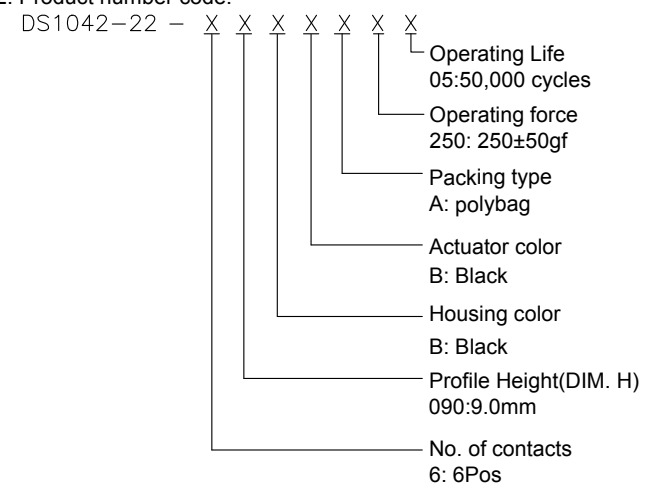

GENERAL TOLERANCE		ANGLE TOLERANCE		PROJECTION		TITLE	10.0*10.5mm
X.	±0.60	X.	±5°	UNITS	mm	Multifunctional Switch SMT Type	
.X	±0.38	.X	±3°	SHEET SIZE	A4	SERIES	DS1042-22 SERIES
.XX	±0.25	.XX	±2°	晨翔电子有限公司 CONNELY CONNELY ELECTRONIC CO. LTD			
DRAWING TYPE		CUSTOMER					
SCALE		1:1					
DRAWING NO.		C-DS1042-22-XXXXX-A					